

REVISIONS			
REV.	DESCRIPTION	DATE	APPROVED
0	INITIAL RELEASE	11-15-2023	SCC

### Part numbering scheme

**BCR1 s - 2x22mm - MP - 5**

- BCR1 - Bulkhead Connector Receptacle, Face Seal
- s - Bulkhead Mtrl (a=aluminum 6061, b=brass, p=peek, s=316 SST, t=titanium)
- 2 - Number of Contacts (2, 3, 4, 4eG, 7, 8)
- 22 - Connector Size
- MP - Male Pin
- 5 - Cable Length "L" in ft

Contact to Wire Assignment  
(Based on ICEA Method 1 Color Code)

Contact #	Wire Color
1	Black
2	White
3	Red
4	Green
5	Orange
6	Blue
7	White w/Black Stripe
8	Red w/Black Stripe

\* 3-WAY: 1-Black, 2-White, 3-Green

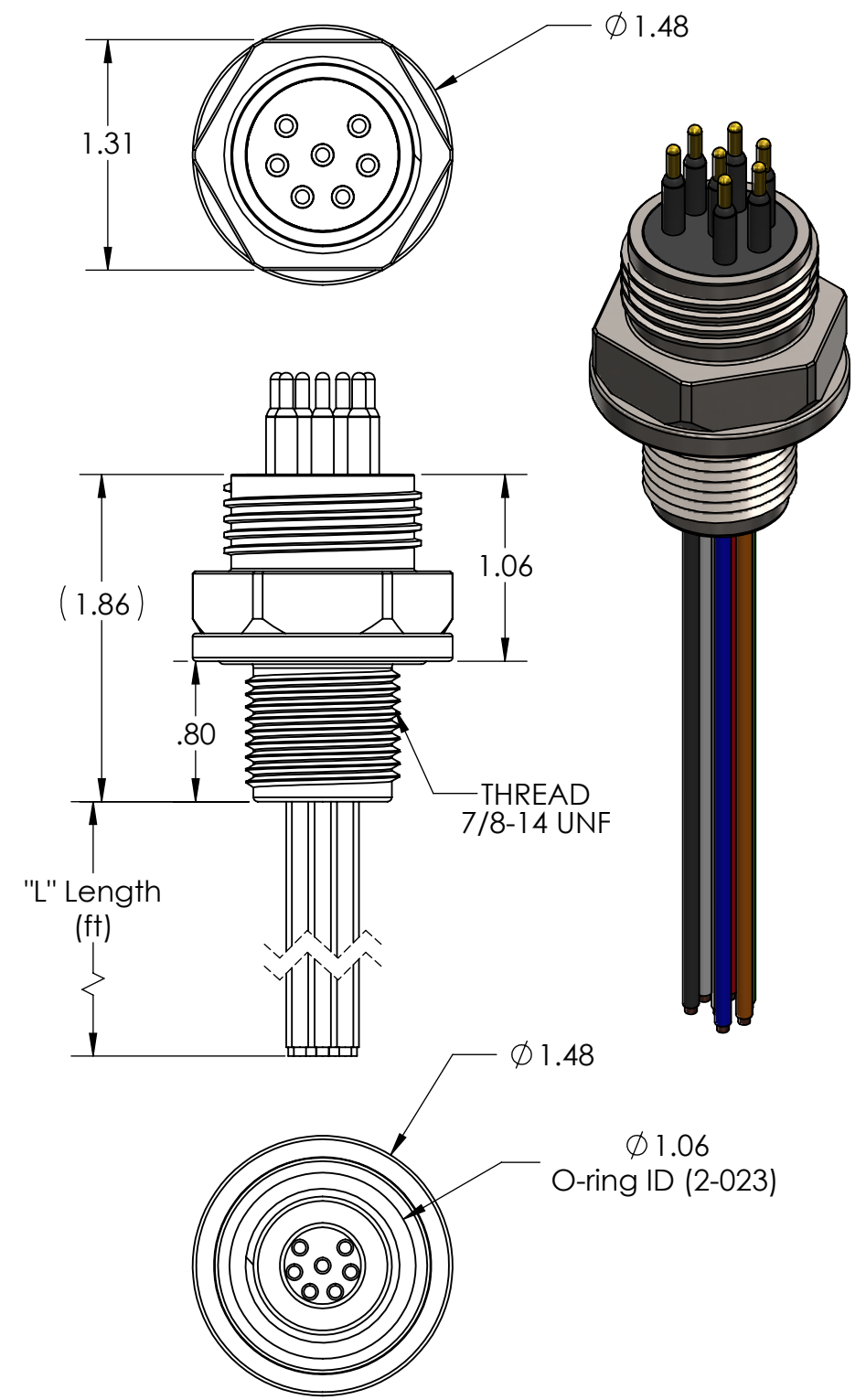
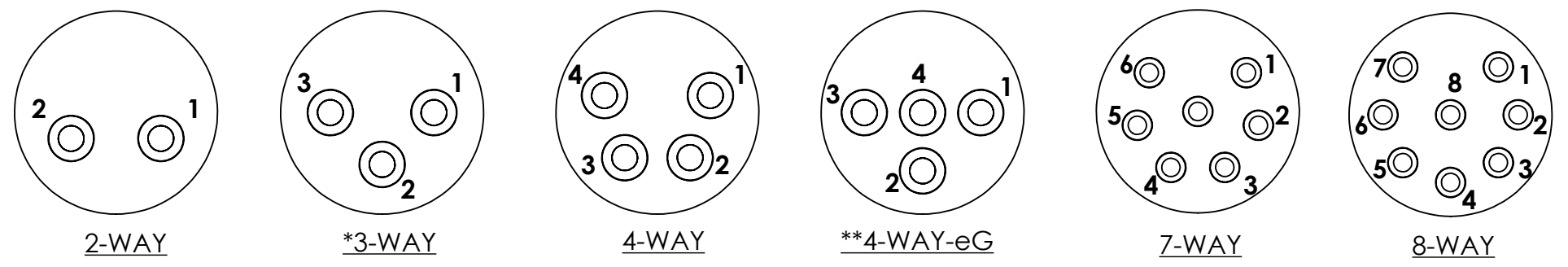

Specifications	
Voltage Rating	600V
Pressure Rating	10,000 psi
Shell Material	(see p/n table)
Contact Material	Gold Plated Cu Alloy
Dielectric Material	Neoprene
Wires	Teflon

**REVISION SYMBOL**

THIS DRAWING CONTAINS PROPRIETARY INFORMATION OF AK INDUSTRIES. USE, DUPLICATION OR DISCLOSURE, IN WHOLE OR IN PART, IS STRICTLY PROHIBITED WITHOUT EXPRESS WRITTEN PERMISSION OF AN AUTHORIZED REPRESENTATIVE OF AK INDUSTRIES.

UNLESS OTHERWISE SPECIFIED DIMENSIONS ARE IN INCHES TOLERANCES ARE:

FRACTIONS	DECIMALS	ANGLES
$\pm 1/16$	.XX $\pm 0.015$	$\pm 1/2^\circ$
	.XXX $\pm 0.005$	
	.XXX $\pm 0.010$	

BREAK ALL SHARP EDGES & CORNERS R.015. ALL DIA. TO BE CONCENTRIC WITHIN .004 TIR.

FINISH 125

DO NOT SCALE DRAWING

THIRD ANGLE PROJECTION  
GD&T IAW ASME Y14.5

ORIGINAL JOB NO.

NAME	DATE
ENGR SCC	6/21/23
CHKD	
APPRV	

AK Industries  
3115 E. Las Hermanas St.  
Rancho Dominguez, CA 90221  
phone: 310-762-1600  
fax: 310-762-1616  
e-mail: info@ak-ind.com

## BCR, 22 mm, Face Seal, Pins

SIZE	FSCM NO.	DWG. NO.	REV
<b>B</b>		<b>BCR1-22mm-MP</b>	<b>0</b>
SCALE:	APPROXIMATE WEIGHT: LBS		SHEET 1 OF 1